

## BRASS SWING CHECK VALVE EPDM GASKET FEMALE BSP PN10

Brass swing check valve for water distribution, watering and heating.  
Brass CW617N-4MS body, strainer and disc for a better strength mechanical.  
EPDM gasket.  
Horizontal or Vertical position with ascendant fluid.



**Size :** DN3/8" to DN4"  
**Connection :** Female BSP  
**Min Temperature :** +0°C  
**Max Temperature :** +60°C  
**Max Pressure :** 10 Bars  
**Specifications :** Horizontal or Vertical Position with ascending fluid  
Swing type  
EPDM gasket (NBR from DN2"1/2 to 4")

**Materials :** Brass CW617N-4MS according to EN 12165

**BRASS SWING CHECK VALVE EPDM GASKET FEMALE BSP PN10**

**SPECIFICATIONS :**

- Brass CW617N-4MS
- Vertical position with ascendant fluid or horizontal position ( respect the flow direction indicated by the arrow )
- Cylindrical threaded female BSP ends
- Swing type
- EPDM gasket (NBR from DN2"1/2 to 4")

**USE :**

- Heating, water distribution and watering
- Min Temperature Ts : + 0°C
- Max Temperature Ts :+ 60°C
- Max Pressure Ps : 10 bars

**RANGE :**

- Swing check valves Threaded BSP cylindrical ends with EPDM seat PN10 from DN3/8" to DN2" **Ref. 302**
- Swing check valves Threaded BSP cylindrical ends with NBR seat PN10 from DN2"1/2 to DN4" **Ref. 302**

**HEAD LOSS GRAPH :**

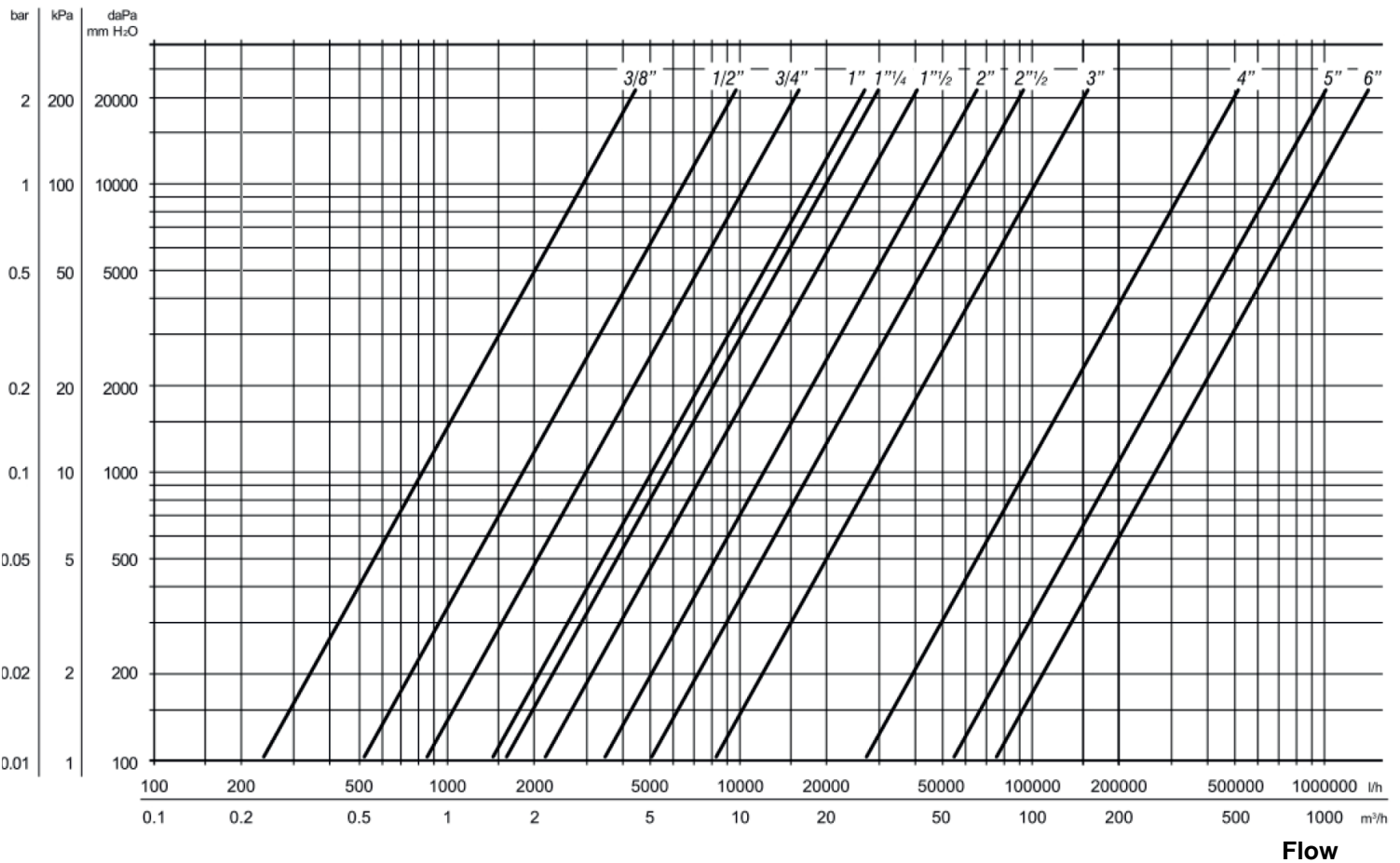

**BRASS SWING CHECK VALVE EPDM GASKET FEMALE BSP PN10**

**FLOW COEFFICIENT Kvs ( M3 / h ) :**

DN	3/8"	1/2"	3/4"	1"	1"1/4	1"1/2	2"	2"1/2	3"	4"
Kvs ( m3/h )	2.9	6.5	10.5	17.8	19.8	26.7	42.8	61.4	103	336

**MATERIALS :**

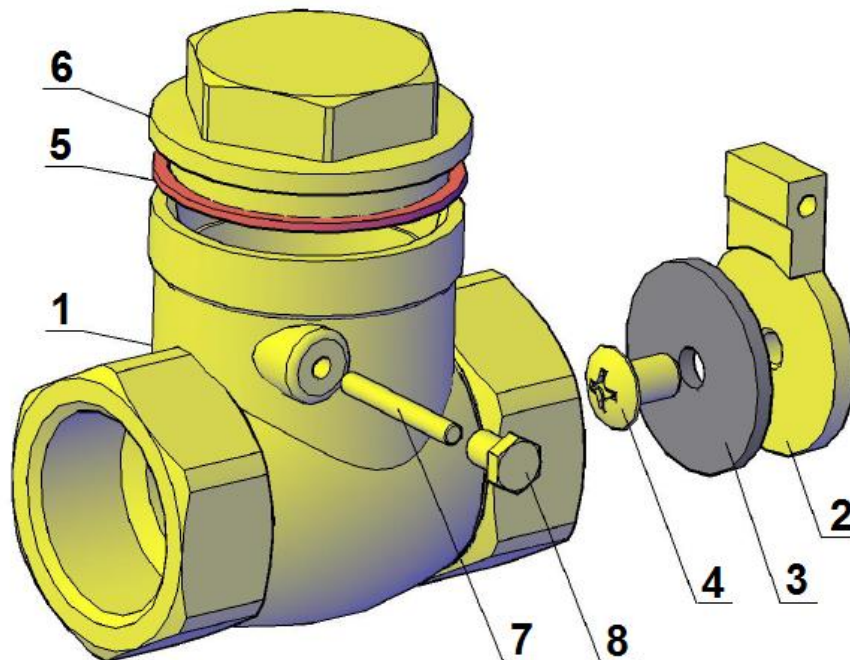

Item	Designation	Materials DN3/8" to 2"	Materials DN2"1/2 to 4"
1	Body	Brass CW617N-4MS according to EN 12165	
2	Disc		
3	Gasket	EPDM	NBR
4	Screw	Brass Hpb59-1	Brass CW614 N according to EN 12164
5	Bonnet gasket	Fibers	NBR
6	Bonnet	Brass CW617N-4MS according to EN 12165	
7	Stem	Brass Hpb59-1	
8	Stem screw		

**BRASS SWING CHECK VALVE EPDM GASKET FEMALE BSP PN10**

**SIZE ( in mm ) :**

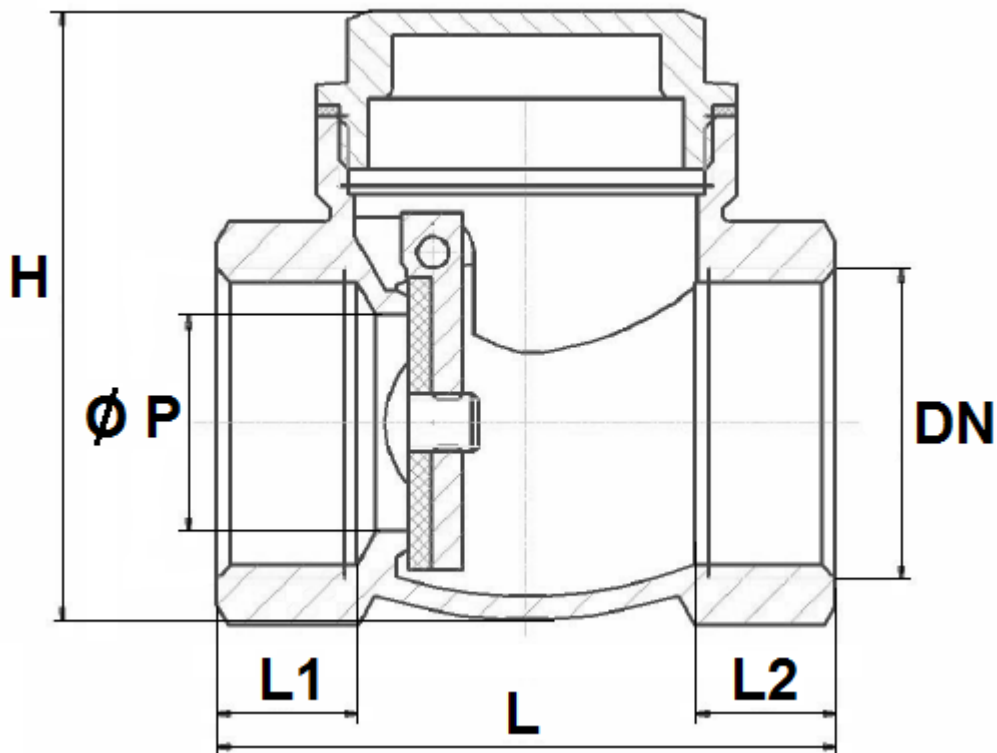

DN	3/8"	1/2"	3/4"	1"	1"1/4	1"1/2	2"	2"1/2	3"	4"
Ø P	12	12.5	18.5	23.5	30	35	47	55	68	88
L	47	47	53	63	70	88	97	116	135	164
L1	10.5	10.5	12	13.5	17	18	19.5	16	16	20
L2	10.5	10	12	12	14.5	17	19.5	16	16	20
H	46	46	52	62	73	92	102	113	133	166
Weight (Kg)	0.12	0.14	0.20	0.34	0.43	0.76	1	1.58	2.25	3.84
Ref.	302003	302004	302005	302006	302007	302008	302009	302010	302011	302012

**BRASS SWING CHECK VALVE EPDM GASKET FEMALE BSP PN10**

**STANDARDS :**

- Manufacturer certified ISO 9001:2015
- DIRECTIVE 2014/68/UE : Products excluded from directive ( Article 1, § 2.b )
- Threaded female BSP cylindrical ends according to ISO 228-1

**INSTALLATION POSITIONS :**

**Vertical position ( ascendant fluid )**

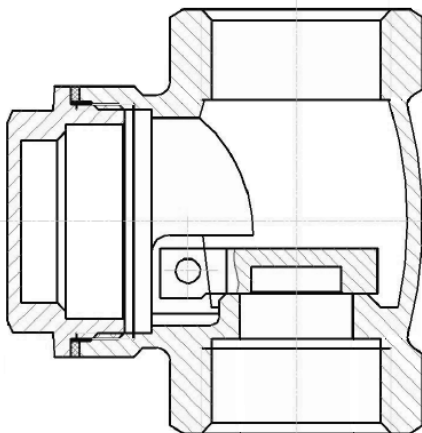

**Horizontal position**

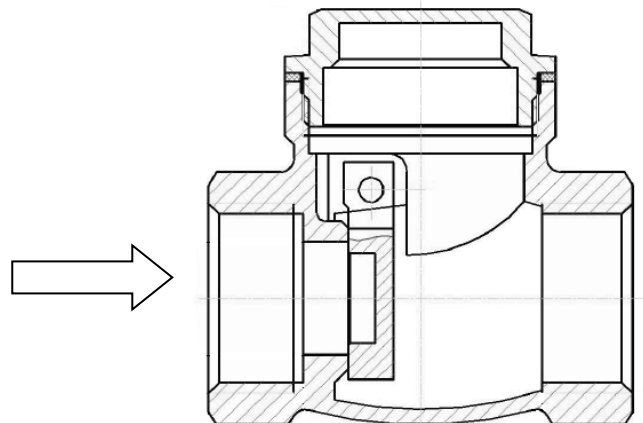

**ADVICE :** Our opinion and our advice are not guaranteed and SFERACO shall not be liable for the consequences of damages. The customer must check the right choice of the products with the real service conditions.